

Type K mit Innenkegel 1:10

with Internal Cone 1:10

avec cône intérieur 1:10

MK MT CM	Ausführung Model modèle	Best. Nr. Order No. no. de com.	Abmessungen Dimensions dimensions			n max RPM max n max min ⁻¹
			D1	D2	L1	
2	2 ST	0217	7	16	7	7000
3	3 SM	0307	7	16	7	7000
	3 ST	0317	12	24	8	5800
4	4 SM	0407	12	24	8	5800
	4 ST	0417	15	30	10	4800
5	5 SM	0507	15	30	10	4800
	5 ST	0517	22	40	15	4000

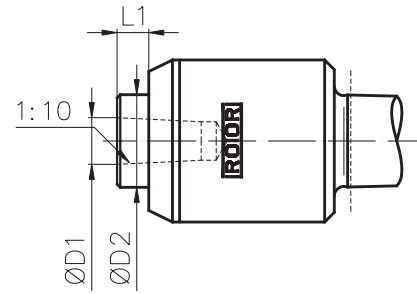

Gehäuseabmessungen siehe Typ N Seite 5

Dimensions of the body see type N on page 5

Dimensions de corps voir type N à la page 5

Einsätze mit Kegel 1:10

Interchangeable Points 1:10

Pointes interchangeables 1:10

Passend zu Suitable for convenant p.	Einsatz Inserts élément	Best. Nr. Order No. no. de com.	Abmessungen Dimensions dimensions								
			d1	l	A	B	C	D	E	F	
2 ST + 3 SM	01	0217-01	7	18	15	17					
	02	0217-02	7	18	14	20	5				
	03	0217-03	7	18	26	19	11		7	3	
	05	0217-05	7	18	14	28	3.8	10			
	06	0217-06	7	18	14	28	4.8	12			
	07	0217-07	7	18	14	28	5.8	14			
	08	0217-08	7	18	14	28	7.8	16			
	09	0217-09	7	18	14	10	6		4	2	
	10	0217-10	7	18	20	20			16	6	
	3 ST + 4 SM	01	0317-01	12	24	25	28				
02		0317-02	12	24	21	32	6				
03		0317-03	12	24	45	29	22		8.2	3.2	
05		0317-05	12	24	21	40	4.8	12			
06		0317-06	12	24	21	40	5.8	14			
07		0317-07	12	24	21	40	7.8	16			
08		0317-08	12	24	21	40	9.4	18			
09		0317-09	12	24	21	17	7.2		4	2	
10		0317-10	12	24	26	26			20	7	
4 ST + 5 SM		01	0417-01	15	30	30	34				
	02	0417-02	15	30	26	38	8				
	03	0417-03	15	30	55	34	28		12	4	
	05	0417-05	15	30	26	49	5.8	15			
	06	0417-06	15	30	26	49	7.8	17			
	07	0417-07	15	30	26	49	9.4	19			
	08	0417-08	15	30	26	49	11.8	22			
	09	0417-09	15	30	26	22	9		5	2.5	
	10	0417-10	15	30	40	39			34	11	
	5 ST	01	0517-01	22	35	38	43				
02		0517-02	22	35	38	57	11				
03		0517-03	22	35	68	42	36		22	6	
05		0517-05	22	35	38	68	7.8	17			
06		0517-06	22	35	38	68	9.4	19			
07		0517-07	22	35	38	68	11.8	22			
08		0517-08	22	35	38	68	14.2	27			
09		0517-09	22	35	38	31	13		8	3	
10		0517-10	22	35	61	58			55	20	

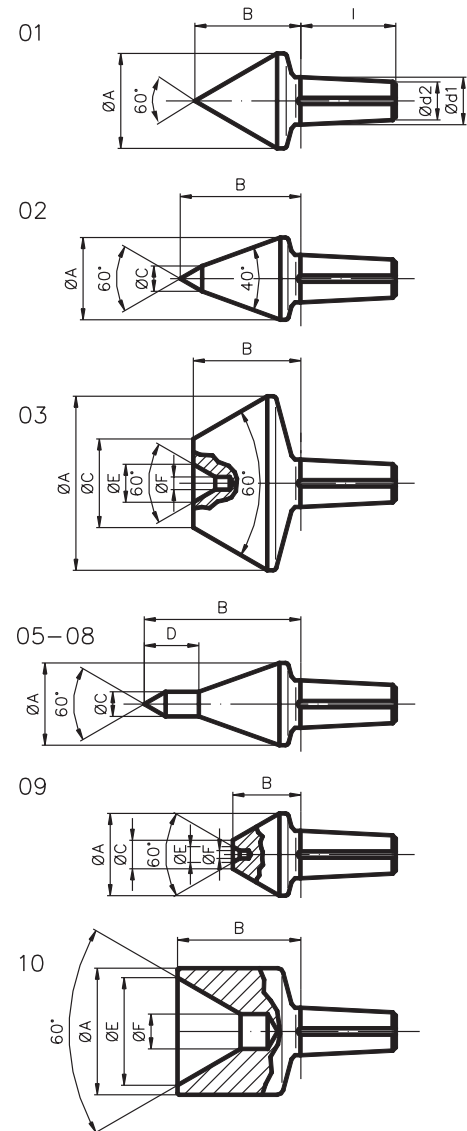

Type K Set / Set / Assortiment

MK MT CM	Ausführung Model modèle	Best. Nr. Order No. no. de com.	Rotierende Aufnahme, Ausheber und folgende Einsätze Live-Centre type K, extractor and following points Contre pointes tournantes type K, extracteur et pièces Interchangeables
2	2 ST	0217-00	01 / 02 / 03 / 05 / 07 / 10
3	3 ST	0317-00	
4	4 ST	0417-00	
5	5 ST	0517-00	

Ausheber / Extractor / Extracteur

Passend zu Suitable for convenant p.	Best. Nr. Order No. no. de com.
2 ST-3 SM	0217-20
3 ST-5 SM	0317-20
5 ST	0517-20