

# ROTOR Präzisions-Spannfutter

## ROTOR High-Precision Chucks

### Mandrin de Précision ROTOR

# Ø150

2 Backen 2.5 mm Hub  
 2 jaws 2.5 mm Stroke  
 2 mors 2.5 mm Course

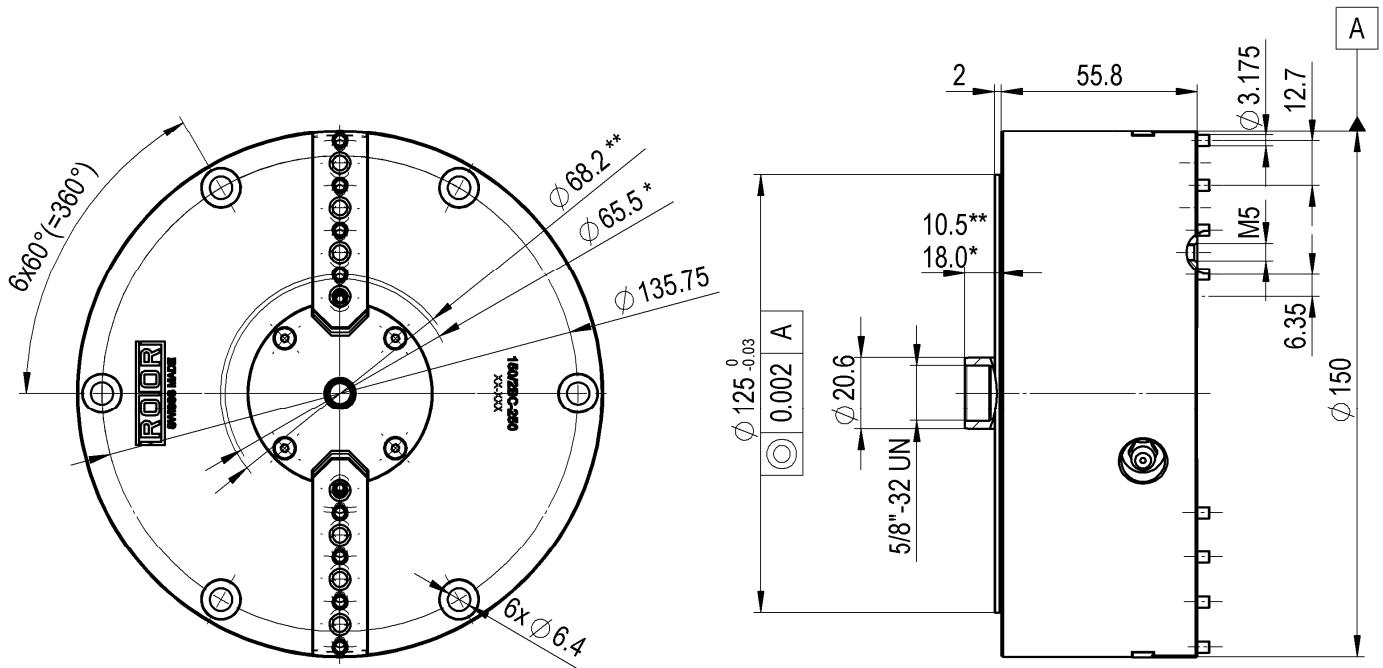

\* geschlossen, closed, fermé, \*\* geöffnet, opened, ouvert

Standard Ausführung Standard type Standard type	Für Kühlmittel-Zufuhr For coolant passage Pour passage arrosage	Für Zentralschmierung Automatic Lubrication Lubrification Automatique	Spannwiederholgenauigkeit Repeatability Répétibilité
Best. Nr. Order No. 150/2B-250 No.de com.	Best. Nr. Order No. 150/2BC-250 No.de com.	Best. Nr. Order No. 150/2BL-250 No.de com.	Typ N < 2 µm Type EP < 1 µm Type

Backenhub im Ø Stroke on diameter Course des mors au Ø	Spannkraft pro Backe Clamp force per jaw Force de serrage par mors	n max RPM max n max	Gewicht Weight Poids	Luftzufuhrrohre Air feed tubes Tubes d'amenée d'air
2.5 mm	600 daN (6 bar)	5'000 min <sup>-1</sup>	6.6 kg	Type B,BC,BL,BS,BSC,BF,BFC

Lieferumfang	Futter- und Backen-Befestigungsschrauben, T-Inbusschlüssel, Prüfprotokoll
Standard Equipment	Chuck and jaw mounting screws, T-handle wrench, Test report
La livraison comprend	vis de montage, clé Inbus, rapport de contrôle

Zubehör	Luftzufuhr-Rohr, Rohr- Führungsflansch und Stützring, Aufsatzbacken, Backen-Ausdreh-Ring, -Bolzen und -Flansch, Handhebel-Ventil und Luft-Wartungs-Einheit, elektro-pneumatische Betätigungs-Einheit, programmierbare Fett-Zentralschmierung (siehe entsprechende Datenblätter)
Accessories	Air feed tube, tube guiding flange and supporting ring, blank top jaws, loading ring and pins, turning fixture, 4/3-way valve, filter- regulator- lubricator-unit, electro-pneumatic control unit, automated lubrication system (see data sheets)
Accessories	Tube d'amenée d'air, douille de guidage et bague de soutien, mors doux, bague et axes de réglage, flasque d'usinage des mors, vanne 4/3-voies, unité filtre -régulateur -lubricateur, unité de commande électro-pneumatique, système de lubrification automatique (selon fiche de données)

Optionen	Kundenspezifische Futter und Aufsatzbacken
Options	Customized chucks and top jaws
Options	Mandrin et mors spéciaux

11.2015



ROTOR TOOL GmbH, Esslingerstrasse 13, CH-8618 Oetwil am See  
 ☎ +41(0)44/929 24 62, Fax +41(0)44/929 15 63, [info@rotortool.com](mailto:info@rotortool.com)  
[www.rotortool.com](http://www.rotortool.com)